

HYDRAULIC EXCAVATOR **SY215CLC** T3



SANY
AMERICA INC.

Rated Power

155 hp / 116 kW

Operating Weight

51,193 lb / 23,221 kg

Dig Depth

21' 8" / 6600 mm

Bucket Breakout

28,551 lbf / 127 kN

SY215CLC DIMENSIONS & SPECIFICATIONS

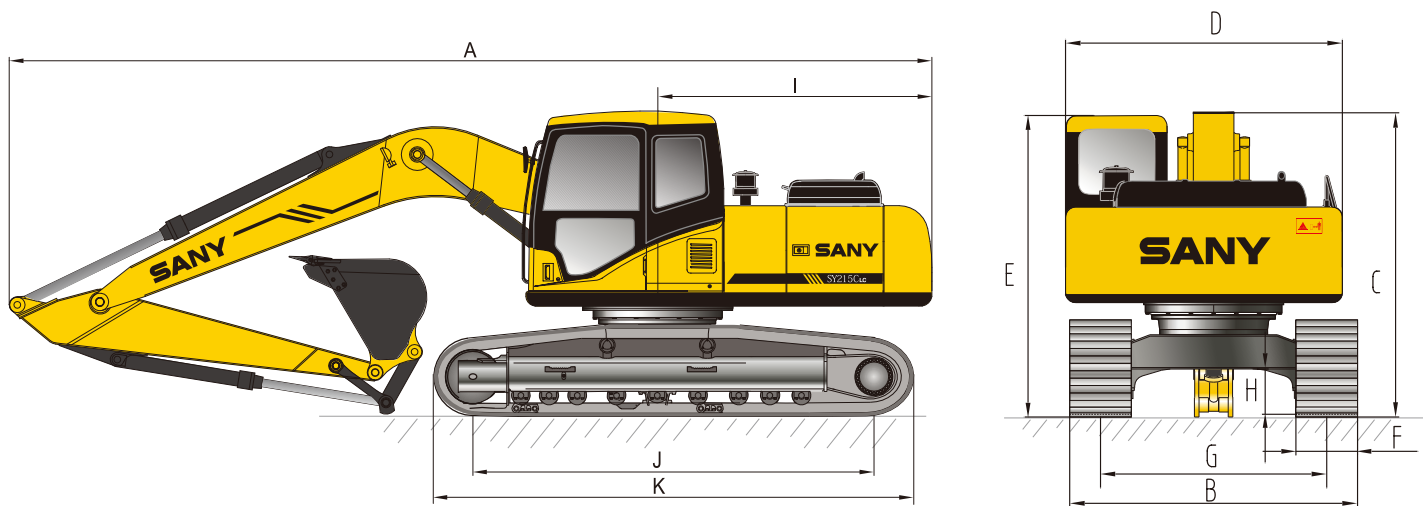

OVERALL DIMENSIONS

A. Transport Length	31' 11" (9728 mm)
B. Transport Width	10' 5" (3180 mm)
C. Transport Height	11' 1" (3370 mm)
D. Upper Width	8' 11" (2710 mm)
E. Cab Height	10' 0" (3050 mm)
F. Track Shoe Width (standard)	31.5" (800 mm)
G. Track Gauge	7' 10" (2380 mm)
H. Minimum Ground Clearance	1' 7" (480 mm)
I. Tail Swing Radius	9' 6" (2890 mm)
J. Length Center Idler to Center Sprocket	11' 11" (3640 mm)
K. Track Length	14' 7" (4450 mm)
Boom Length	18' 8" (5700 mm)
Arm Length (standard)	9' 7" (2925 mm)

MACHINE PARAMETERS

Operating Weight	51,193 lb (23221 kg)
Engine Type	Cummins QSB6.7 T3
Engine Rated Power (Gross)	155 hp (116 kW) @ 1950rpm
Engine Max Torque	456 lbf (618 Nm) @ 1500 rpm
Engine Displacement	408 in ³ (6.7 liter)
Alternator	50A/24V
Main Pump Flow	2 x 55 gpm (2 x 203 lpm)
Swing Speed	10.1 rpm
Travel Speed	1.9/3.3 mph (3.1/5.3 km/h)
Tractive Effort	40,466 lbf (180 kN)
Max Arm Digging Force (ISO)	23,155 lbf (103 kN)
Number of Upper Rollers	2
Number of Lower Rollers	9
Fuel Tank Capacity	90 gal (340 liter)
Hydraulic Tank Capacity	61 gal (230 liter)
Cooling System Capacity	7.3 gal (27.6 liter)
Engine Oil Capacity	7.0 gal (26.4 liter)
Ground Pressure (31.5"/800mm shoes)	5.3 psi (36.3 kPa)

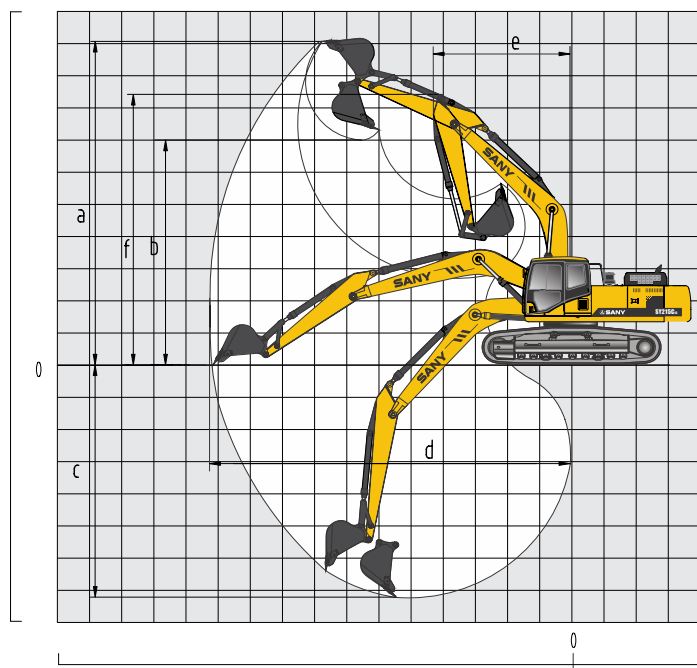

WORKING RANGE

a Maximum Digging Height	30' 1" (9180 mm)
b Maximum Dumping Height	21' 10" (6670 mm)
c Maximum Digging Depth	21' 8" (6600 mm)
d Maximum Vertical Wall Digging Depth	19' 7" (5980 mm)
e Maximum Digging Reach	33' 10" (10307 mm)
f Minimum Swing Radius	12' 2" (3730 mm)
g Maximum Height at Minimum Swing Radius	25' 2" (7680 mm)



SANY
AMERICA INC.

318 Cooper Circle
Peachtree City, GA, 30269
www.sanyamerica.com